

# Custom Repetition

Create your own custom repetitions

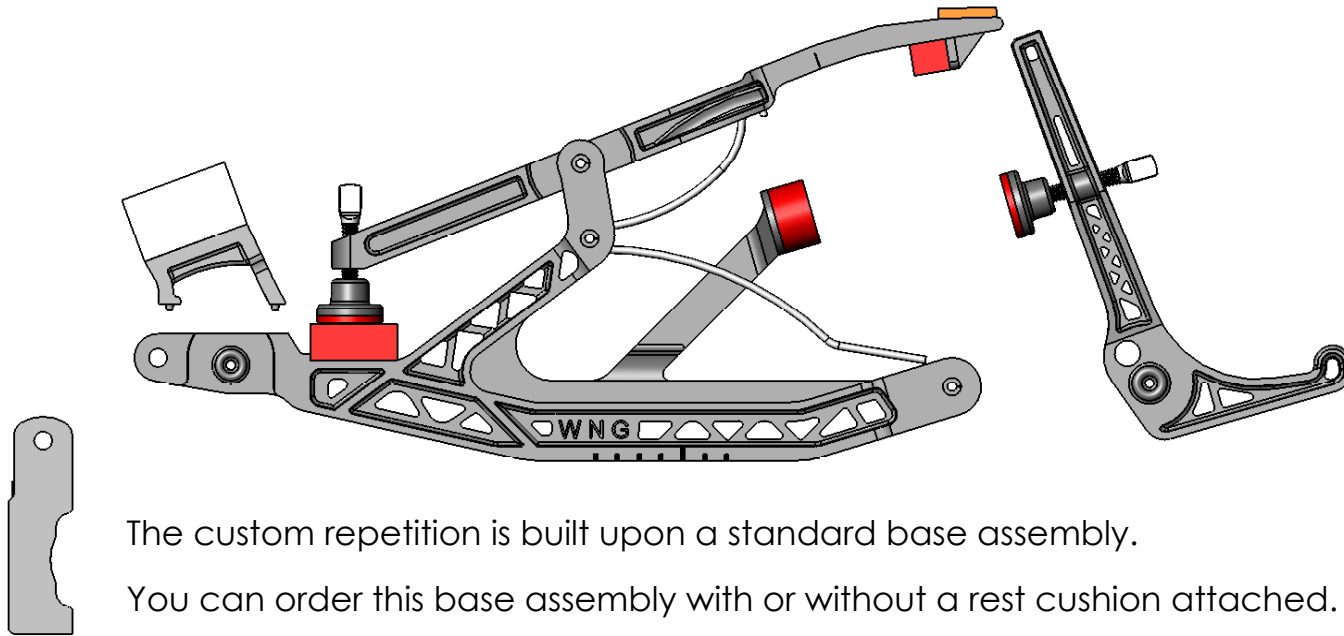

The custom repetition is built upon a standard base assembly.

You can order this base assembly with or without a rest cushion attached.

The flange and jack of your choosing will be pinned onto the base assembly by WNG.

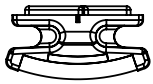

To the standard base you will need to select a heel or heel combination.

1. It is possible to have a one size heel for the sharps and another heel size for the naturals to control the half stroke line for each.
2. It is your choice as whether or not the heels ship attached.
3. The Custom Repetition is assembled to your order so allow at least 3 weeks for assembly and shipping.

Follow the steps to define a custom repetition

# Custom Repetition

Create your own custom repetitions by selecting the desired components

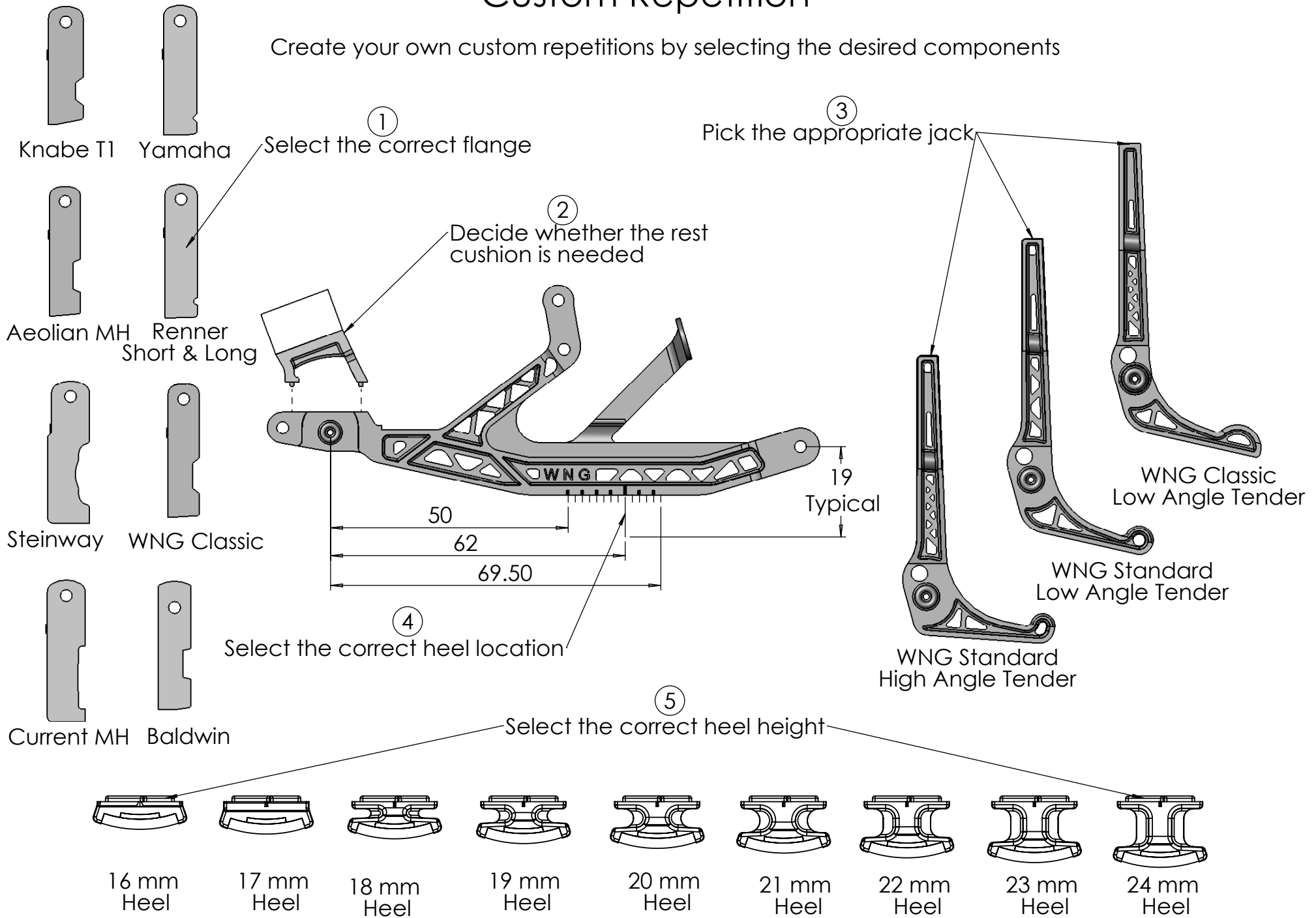

# Custom Repetition Step #1

Decide whether the rest cushion is needed

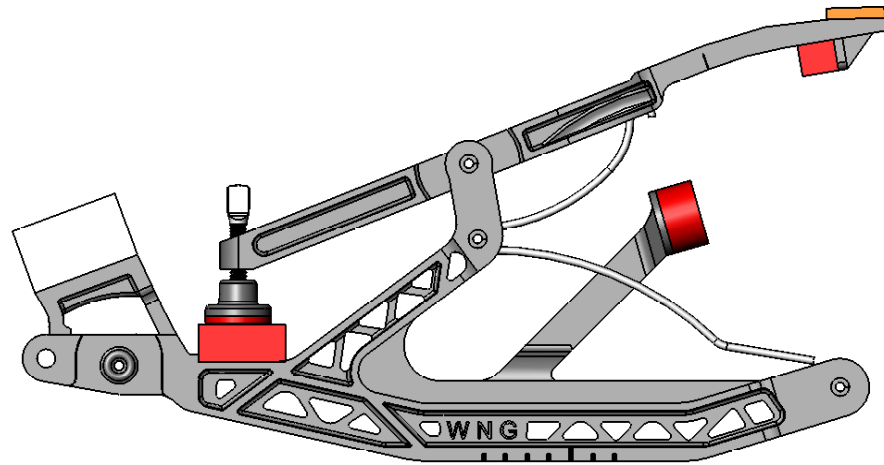
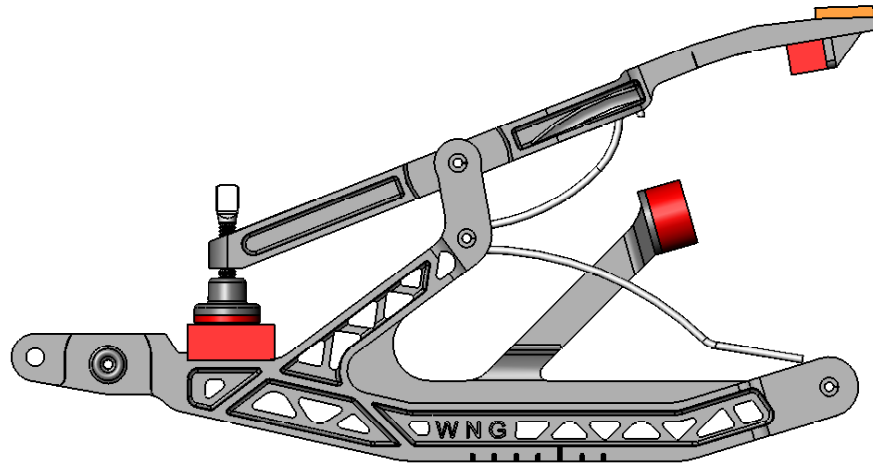

# Custom Repetition Step #2

Select the correct flange



Current MH



Steinway



Aeolian MH



WNG Classic



Renner Short



Renner Long



Knabe T1

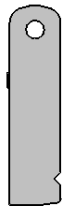

Yamaha

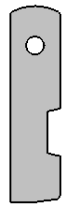

Baldwin

# Custom Repetition Step #3

Pick the appropriate jack

## WNG Standard Jack

Most commonly used jack in the world

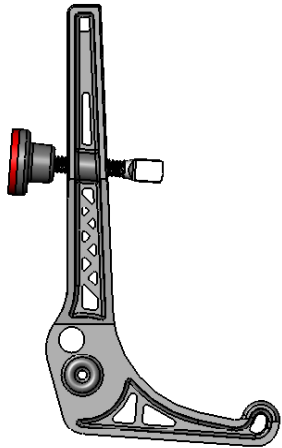

High Angle Tender

## WNG Modern Jack

Same as Standard Jack except with a low angle tender

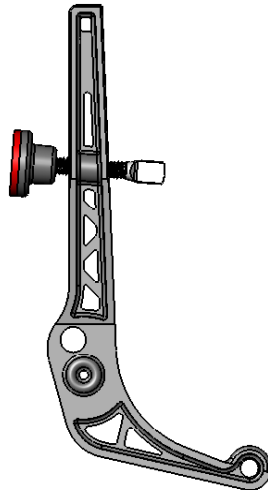

Low Angle Tender

## WNG Classic Jack

Same shape, length and tender as found on WNG Classic actions

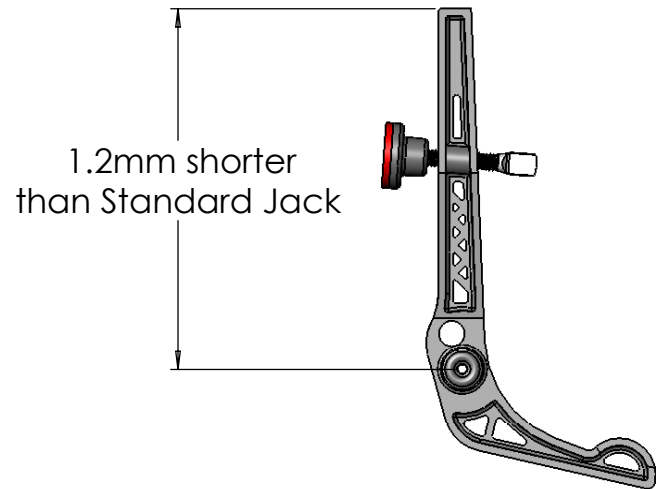

WNG Classic Jack shape  
Low Angle Tender

## Custom Repetition Step #4

Select the correct heel

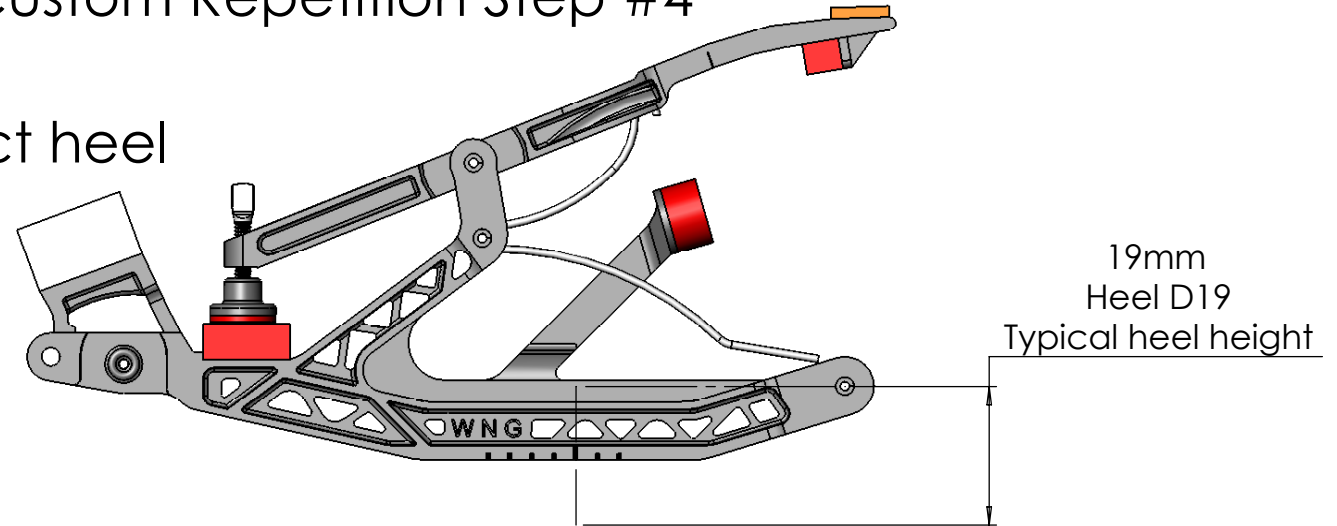

WNG provides 9 different vertical heel sizes in 1mm increments.

It is possible to select different heights for the naturals and the sharps.

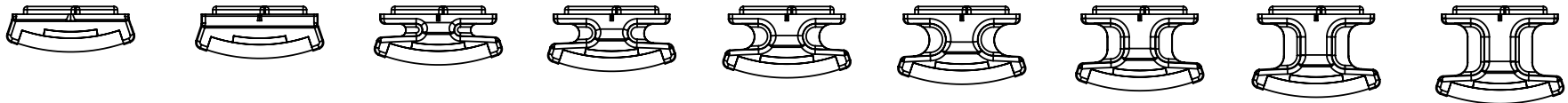

16 mm Heel A16	17 mm Heel B17	18 mm Heel C18	19 mm Heel D19	20 mm Heel E20	21 mm Heel F21	22 mm Heel G22	23 mm Heel H23	24 mm Heel I24
88	88	88	88	88	88	88	88	88
52	52	52	52	52	52	52	52	52
36	36	36	36	36	36	36	36	36

To select the same size heel for all 88 notes simply select 88 under the correct size.

If you wish to have a different size for the sharps than for the naturals  
Select 36 under the sharp size and 52 under the natural size.

# Custom Repetition Step #5

WNG provides 14 horizontal locations for the heel

If you wish WNG to assemble the heel to the Standard Base then select from the following dimensions for the center of the heel

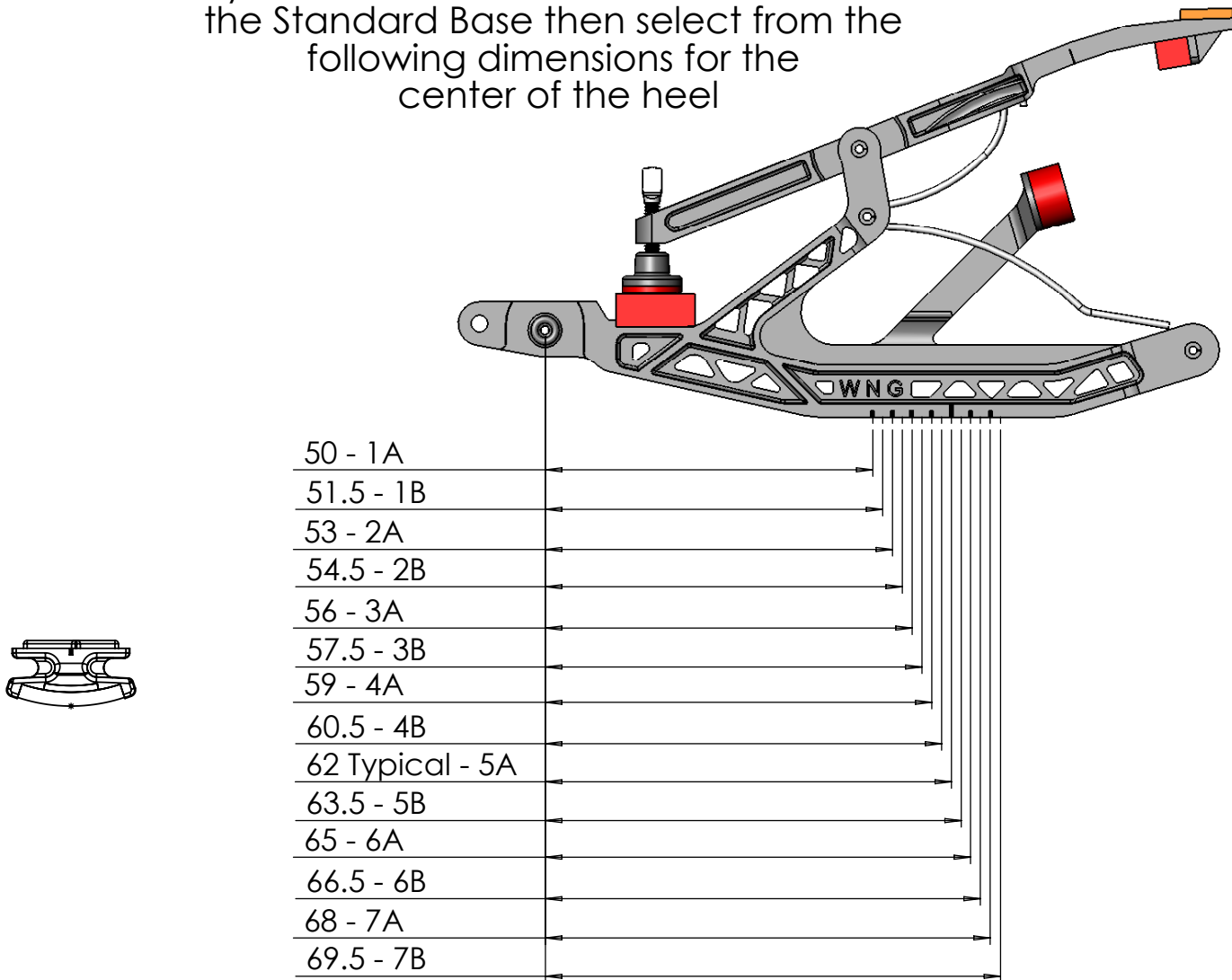

## Custom Repetition Summary

Make sure that this repetition has the features you want.

You have ordered:

1. A standard base with a rest cushion.
2. A Steinway flange.
3. A Standard High Angle jack.
4. 19mm Heels - Qty 52
5. 21mm Heels - Qty 36
6. Heels installed in location 5A by Customer

To modify the features selected

To complete the order